

gripsport®

Assembly Instructions

GSE & GSE+

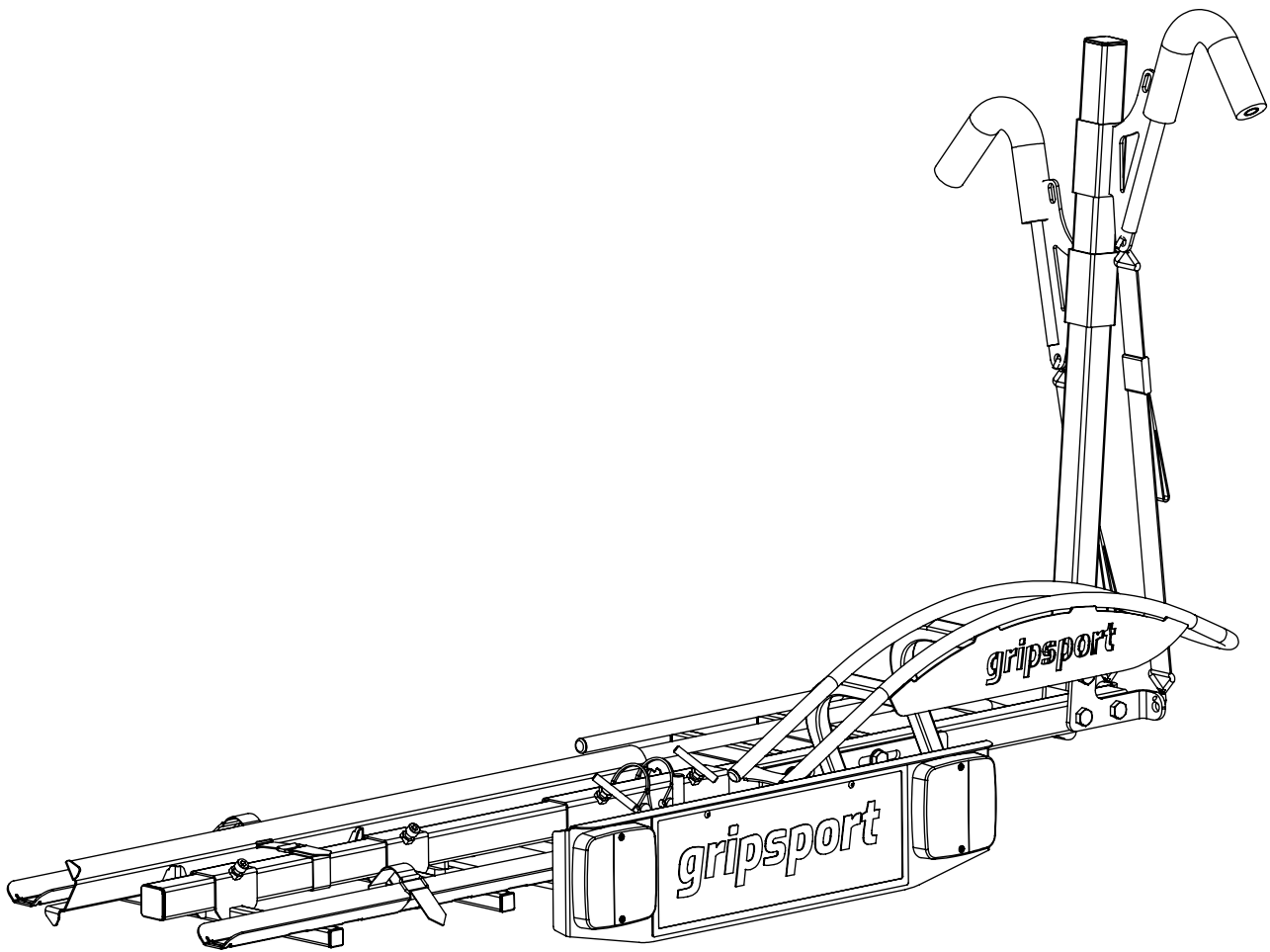

Max. 30kg , Per bike

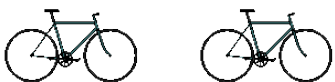

Parts list

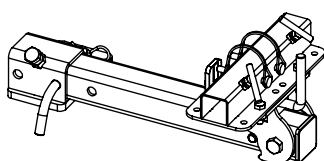
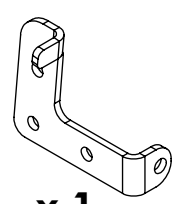
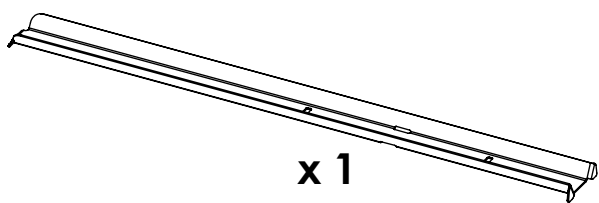
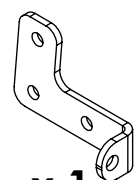
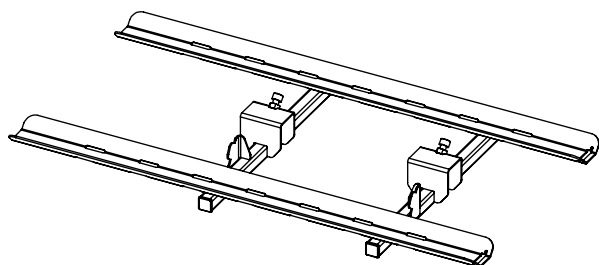
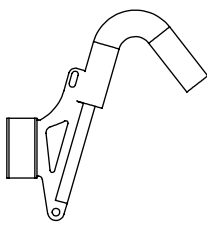
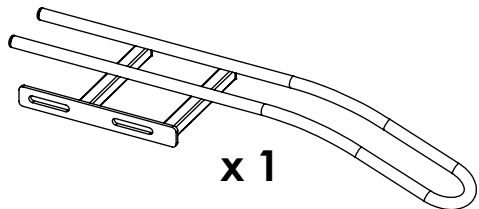
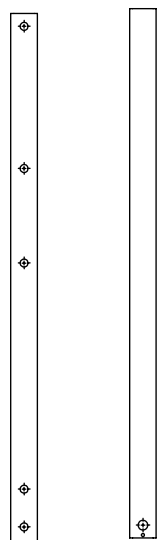
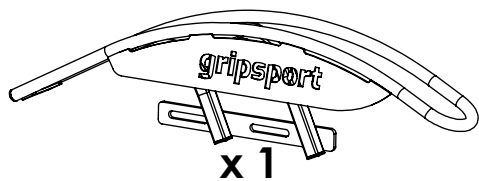

Tongue QR hitch

or

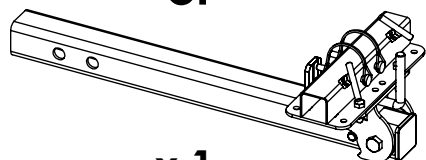

50mm Square QR hitch

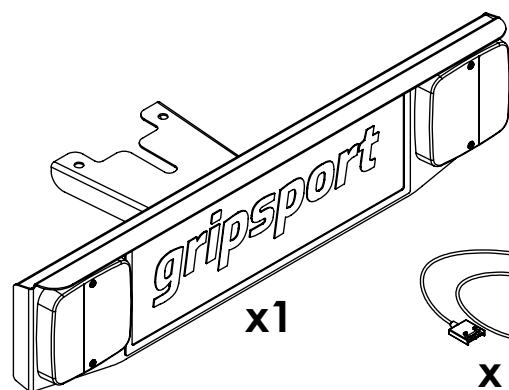
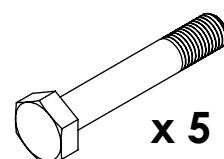

GSE+ only

Fit 'tongue QR hitch' to your tow ball tongue (using your own tow ball)

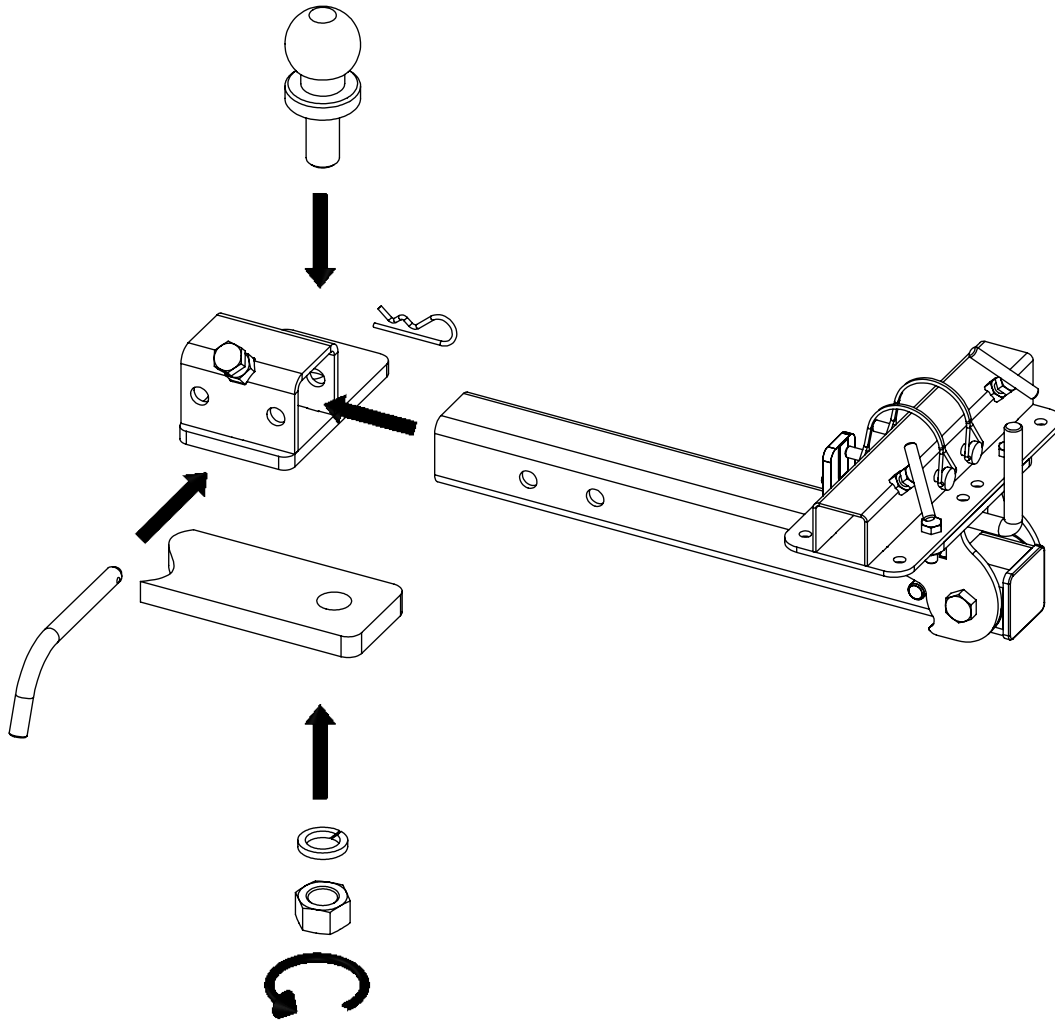

OR

Fit 50mm Square QR hitch' to your receiver

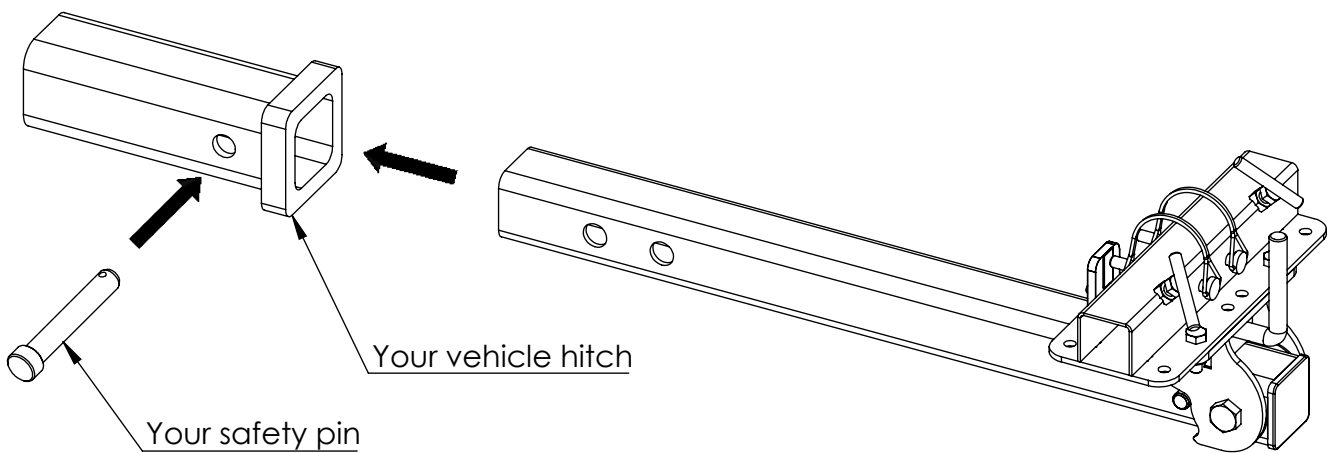

Fitting Arms

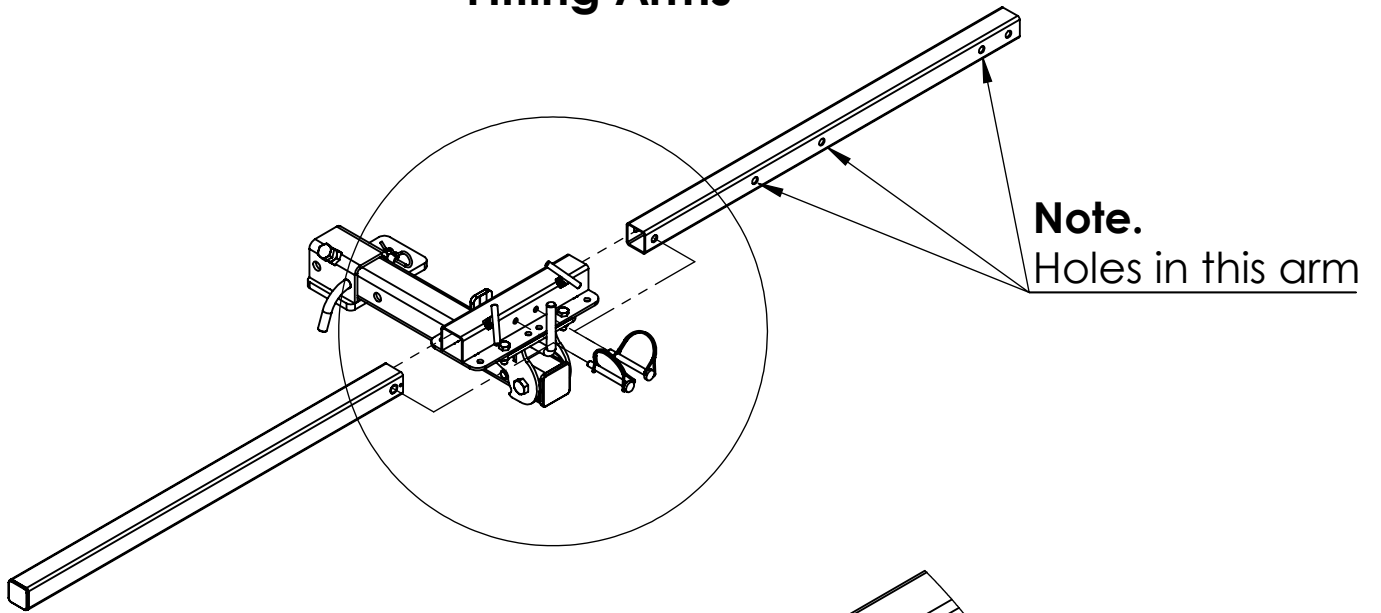

Tighten firmly

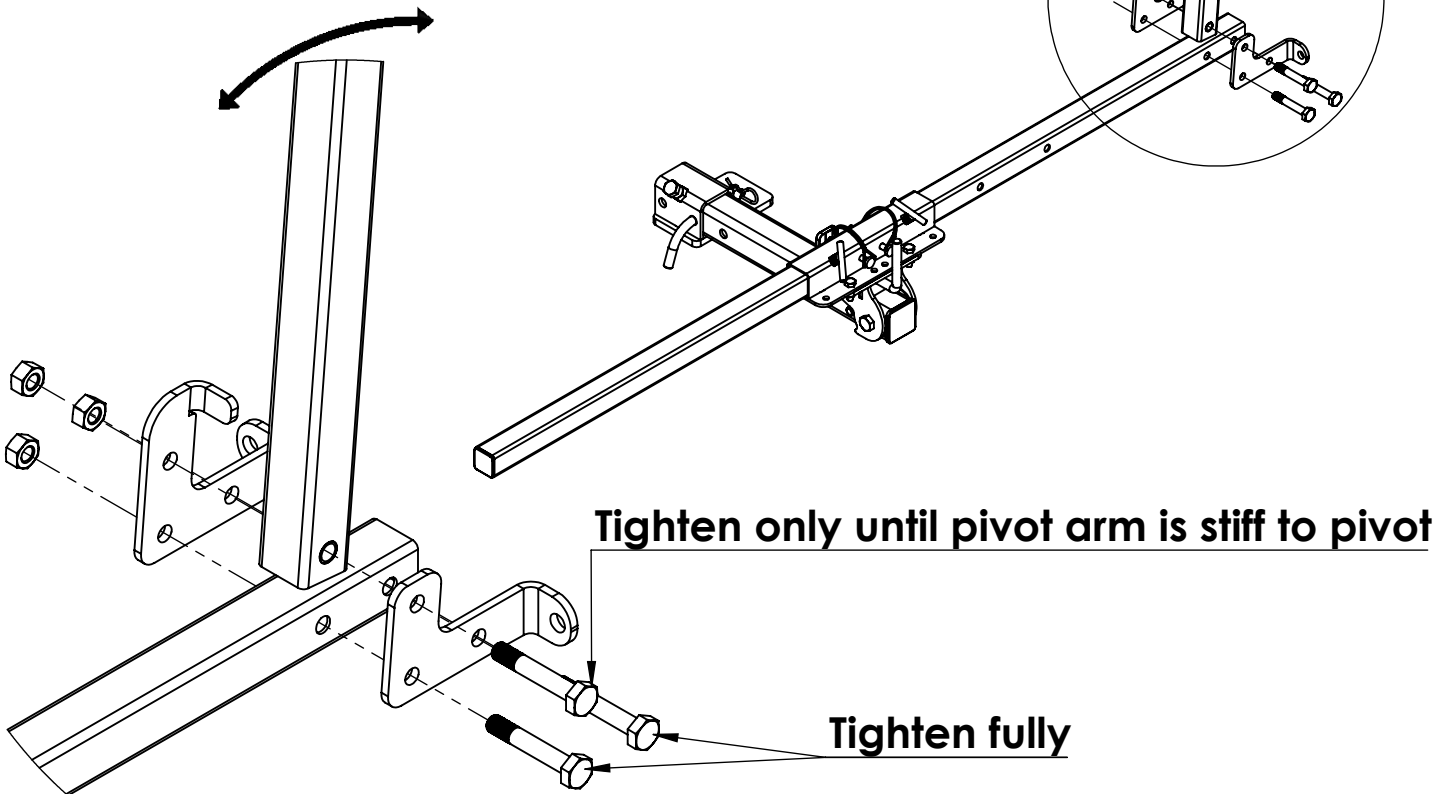
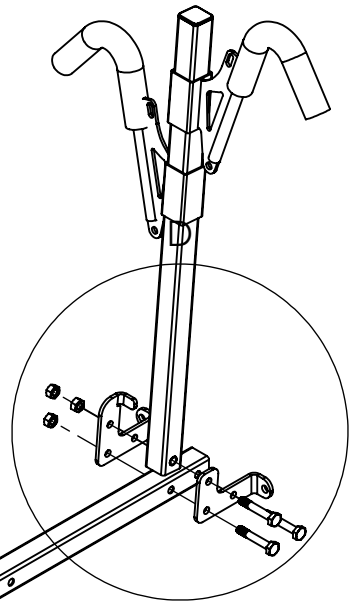
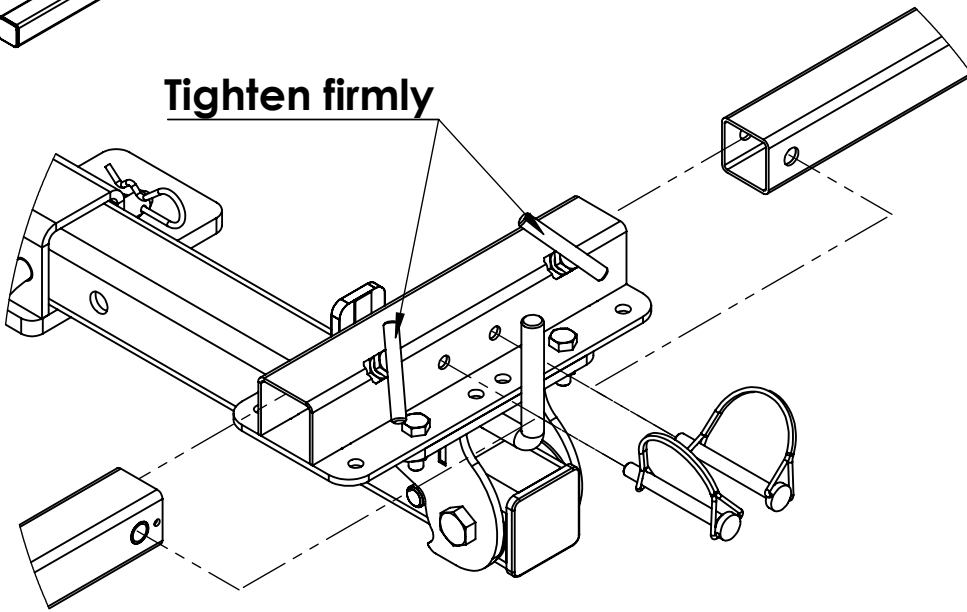

Fitting Hoops & Track

Fit track onto arm

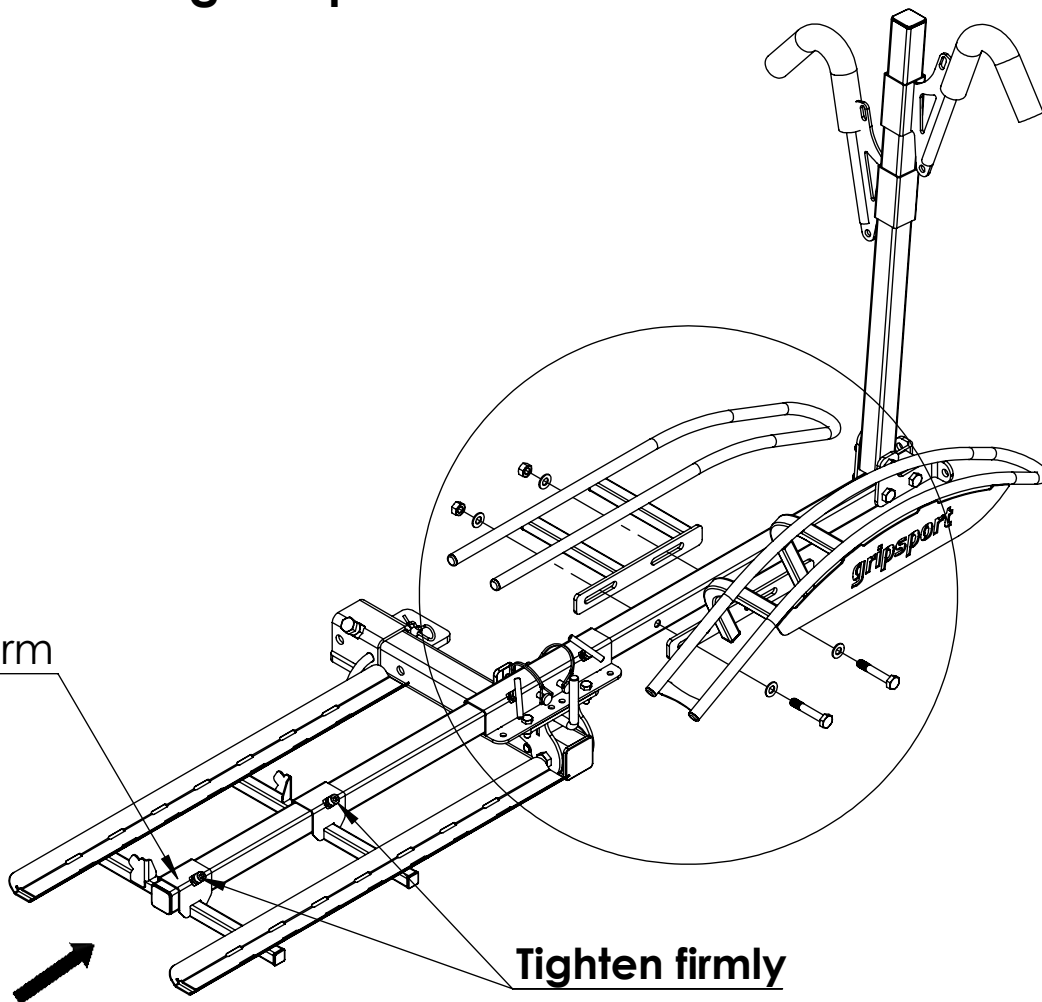

Fit hoops to arm

Note washers.

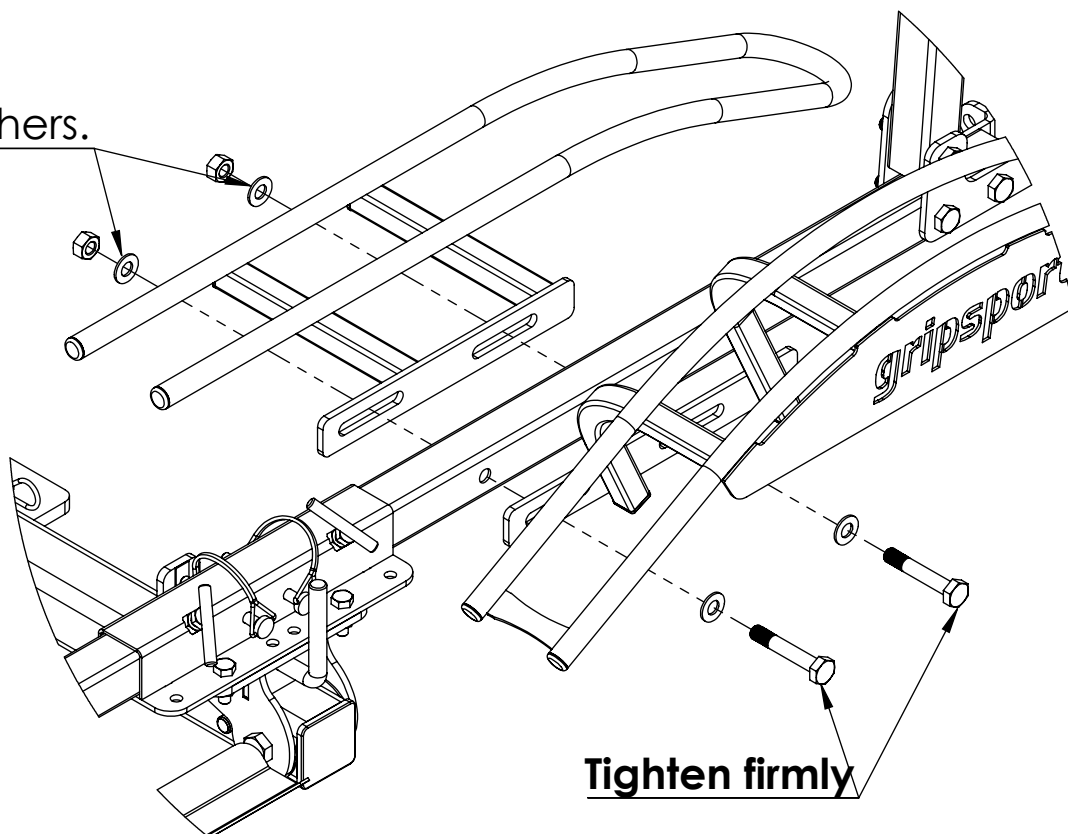

Loading Bikes

Thread cinch strap through track.

Position pivot arm.

Note. Arm **MUST** be against stop.

Fit Ramp

Place hook over front wheel

Load bike closest to vehicle first

Note. Always place **FRONT** wheel in hoop.

Tighten cinch strap around wheel rim.

Note. Strap **MUST** be as close to lowest part of wheel as possible.

Fit tie-down strap
Tighten firmly

Attention !

- Make sure tyres are inflated to recommended pressure.
- This carrier is NOT designed for off road use.
- Maximum carrying capacity 30Kg per bike.
- Tighten everything & check often.

Repeat with second bike

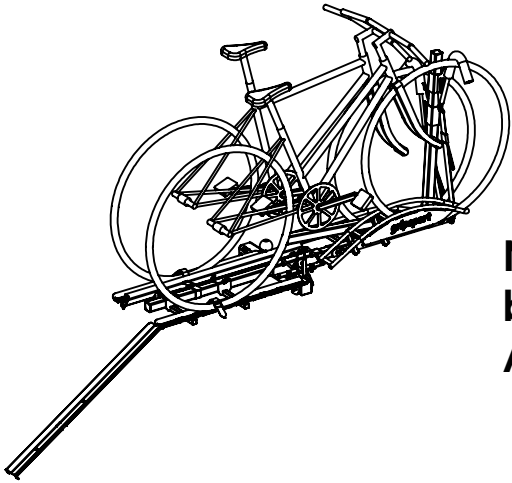

NOTE. There must be a gap between the hooks.
Adjust bike position if necessary.

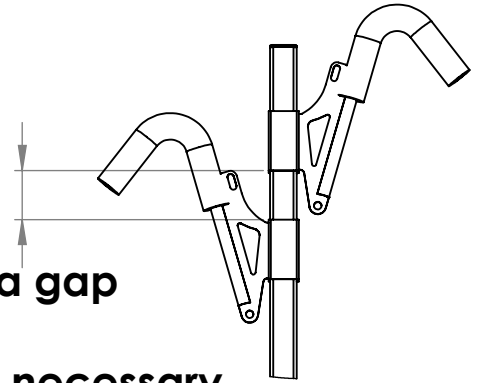

Stow ramp on carrier & secure with cinch strap when travelling.

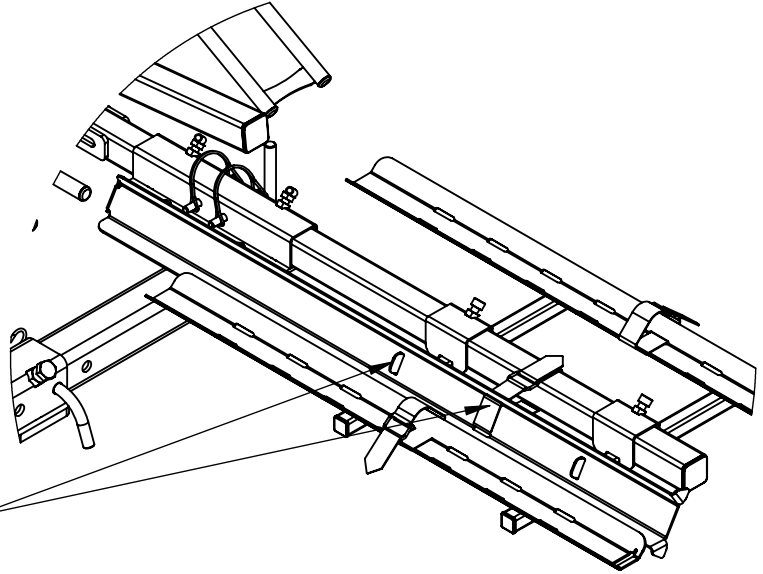

Fitting Rack Light (GSE+ only)

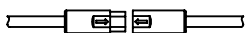
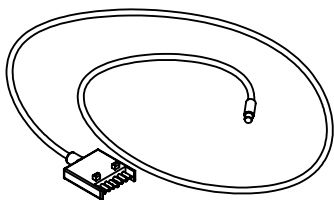
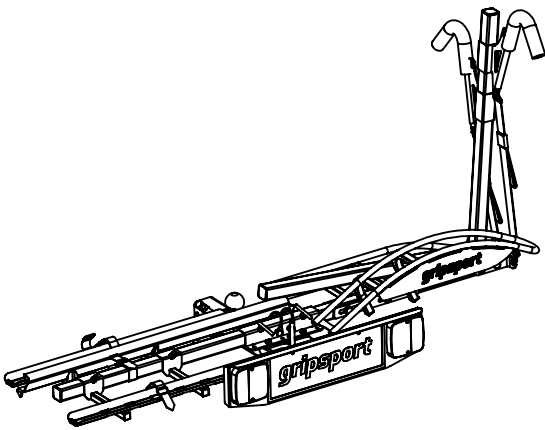

Connect plug to wiring loom

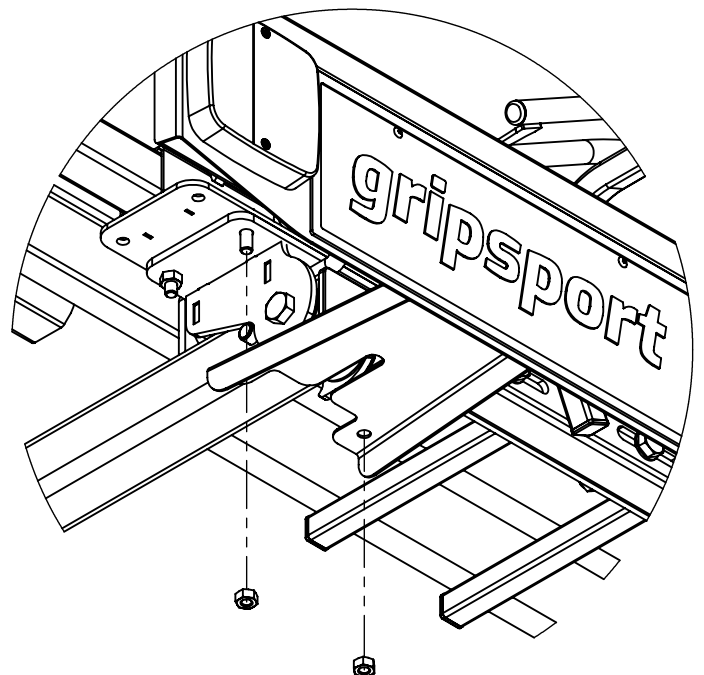

Tilt Function

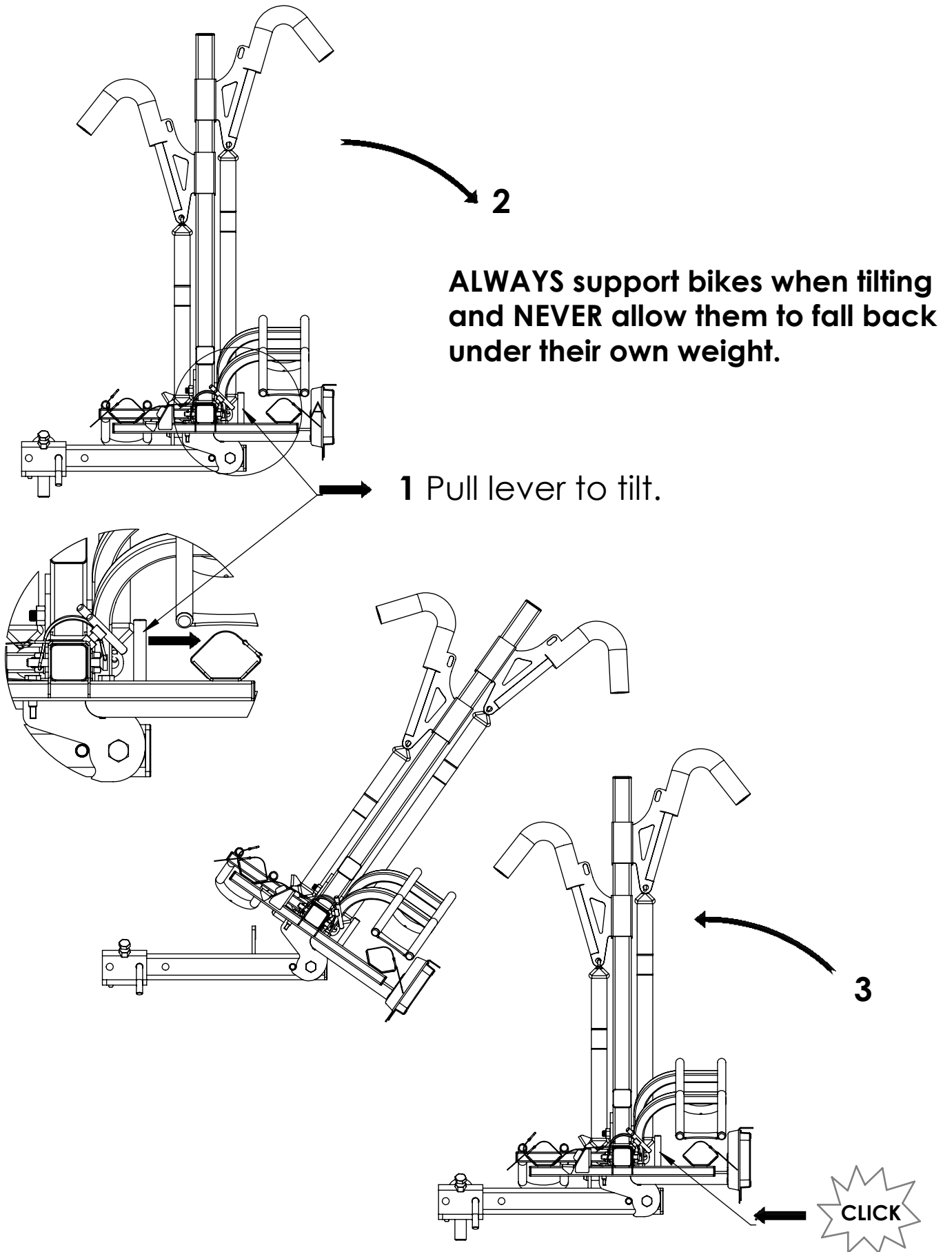

Check rack is locked in upright position before driving.

Breaking rack down

1. Remove hooks & tie down straps

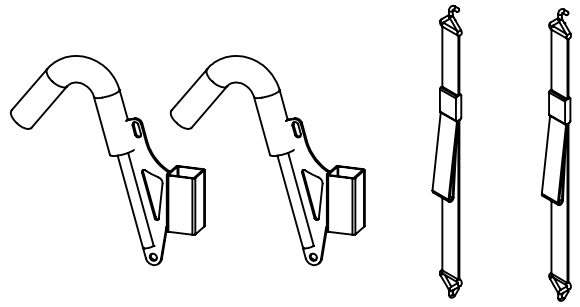

2. Remove pins

3. Loosen T-bolts

5. Fold pivot arm down

6. Remove hoop assembly

7. Remove centre assembly

4. Remove track assembly

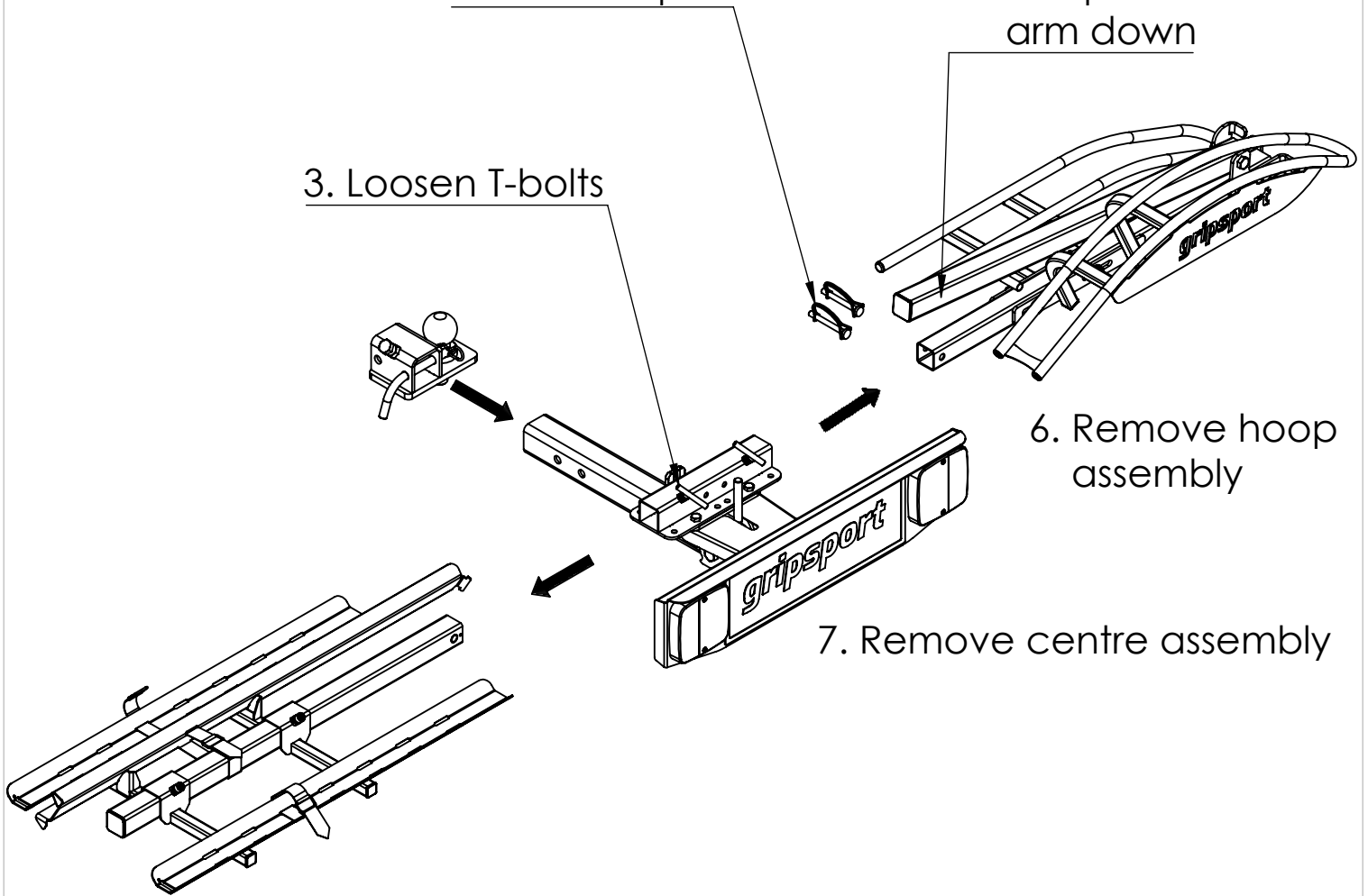

Assembly is reverse of above.

Adjusting Rack

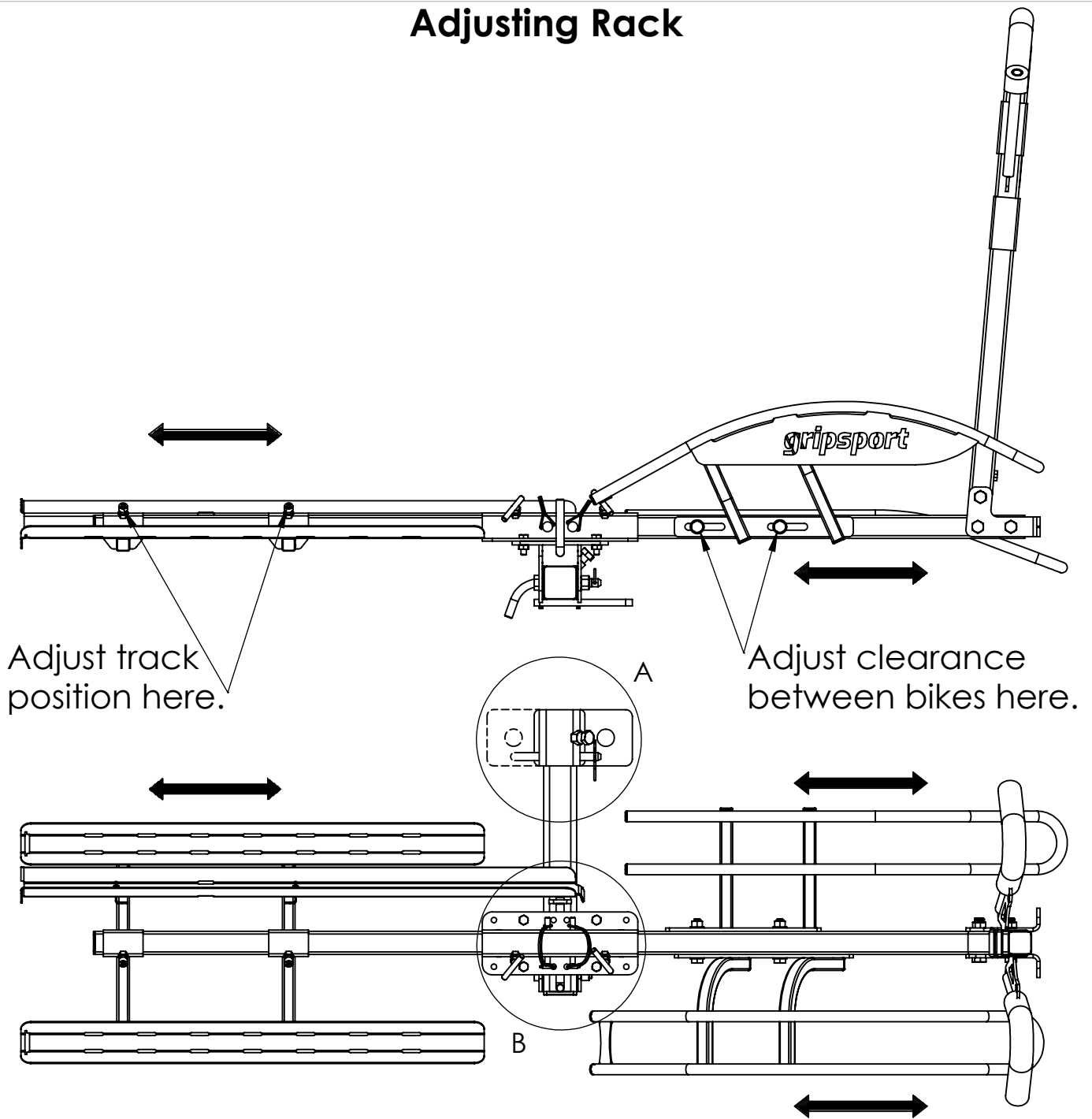

To centre rack on vehicle.

Rotate Tongue QR Hitch 180°
on towbar tongue

and / or

Undo bolts &
Reposition centre assembly

