

# Versa Vertical Bike Rack

**gripsport**

**Pictured:  
4 bike rack with optional  
Wheel Hoop Reducer**

**⚠ HEAVY ⚠**  
40kg Rack Weight  
2 person lift advised

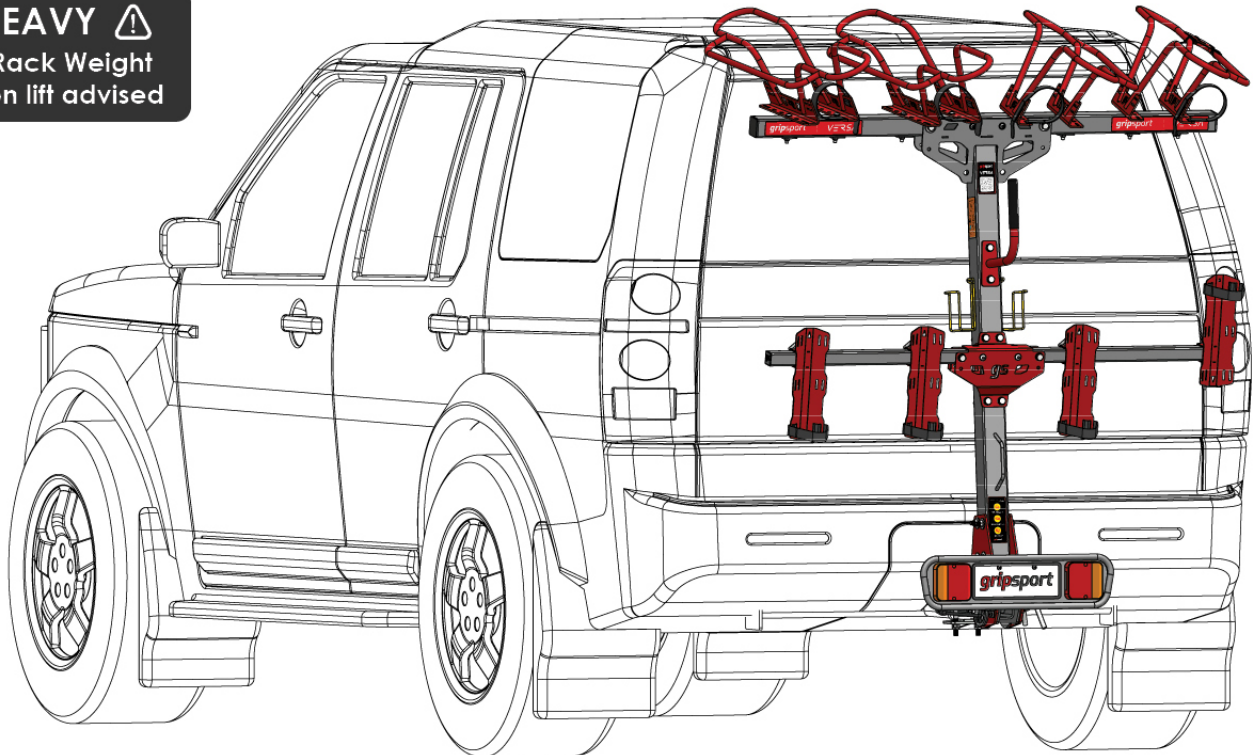

## Tools required:

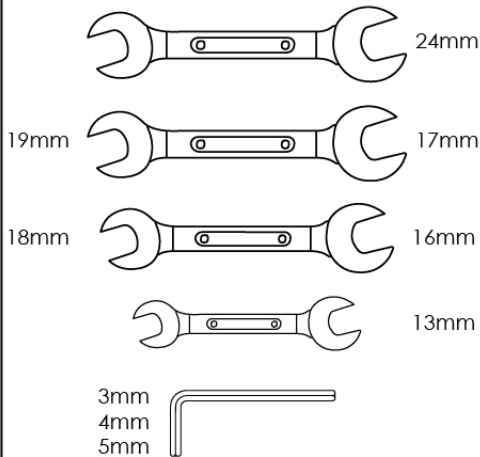

**Rated: 25kg per bike spot**  
**50x50mm Square Hitch Mount only**  
**Light Off-Road use limited**  
**Check Vehicle & Tow Bar Rating**

**Warranty:**  
**5 year limited lifetime.**  
**See all details online at:**  
[www.gripsport.com.au/terms-conditions](http://www.gripsport.com.au/terms-conditions)



[facebook.com/gripsport.real](https://facebook.com/gripsport.real)



[@gripsportbikeracks](https://www.instagram.com/gripsportbikeracks)



[bit.ly/GripSportVideos](https://bit.ly/GripSportVideos)

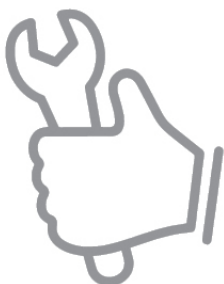

Hand tools assembly only.  
Do not use power tools.



Read and refer to this manual to ensure correct assembly and installation.  
See also: [Fitting Guide](#)



Danger of accident and injury if these instructions are not followed. If unsure, contact gripsport or get a qualified installer to assist.



website info at:  
[www.gripsport.com.au](http://www.gripsport.com.au)

# Versa 1.4 - Parts List

**gripsport**

**4 Bike Vertical Rack quantities shown below.**

2 and 6 Bike Vertical Rack quantities vary accordingly.

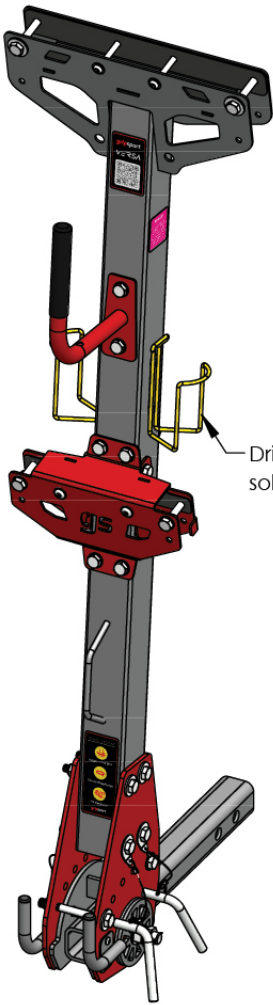

Drink bottle cages  
sold separately

**1 x Mast Assembly**  
(loosely fitted bolts for Arms)

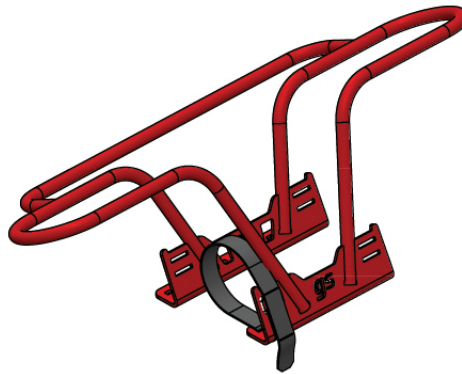

**4 x Wheel Baskets**  
(WrapStraps pre-fitted for use on large wheel channel)

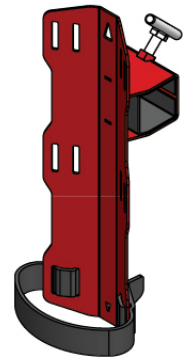

**4 x Taquitos**  
(WrapStraps pre-fitted for use on long wheelbase lengths)

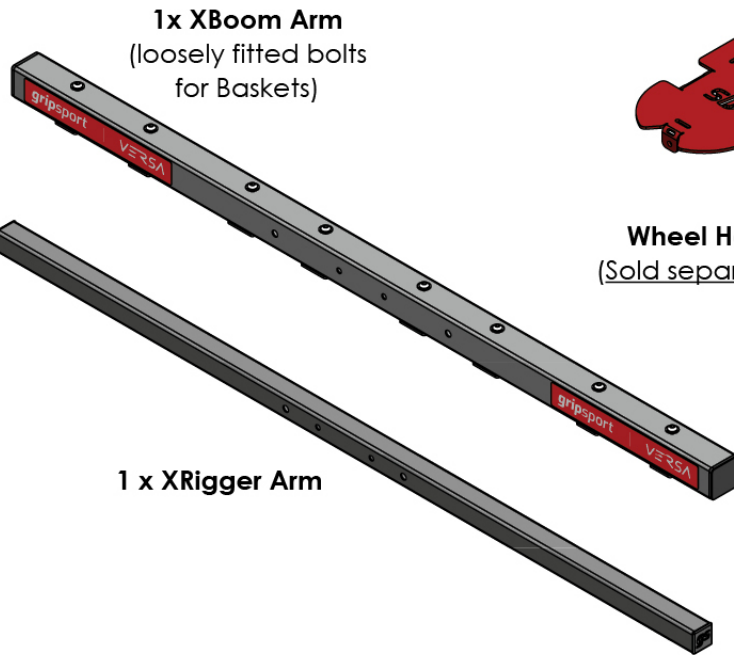

**1x XBoom Arm**  
(loosely fitted bolts for Baskets)

**1 x XRigger Arm**

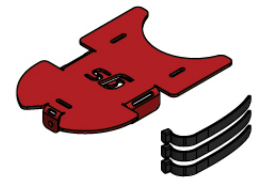

**Wheel Hoop Reducer**  
(Sold separately as a pair)

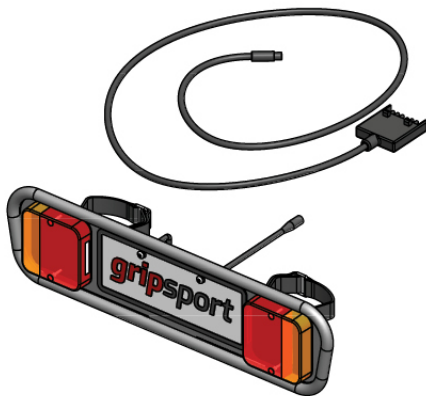

**1 x Rack Light with detachable cable and 7-pin Flat plug connector**  
(mount low on rack else directly on bikes)

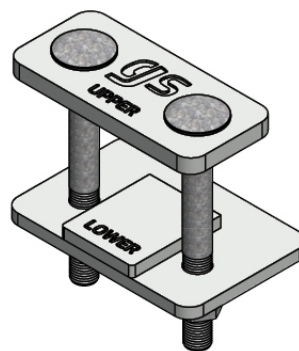

**1 x Hitch Clamp**

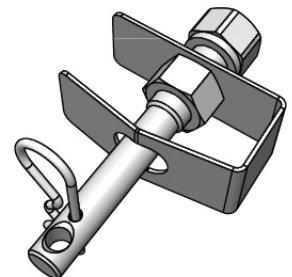

**1 x Hitch Stabiliser**  
(with extra hole for padlock)

# 1. Install Hitch Stabiliser, Hitch Arm & Hitch Clamp

**gripsport**

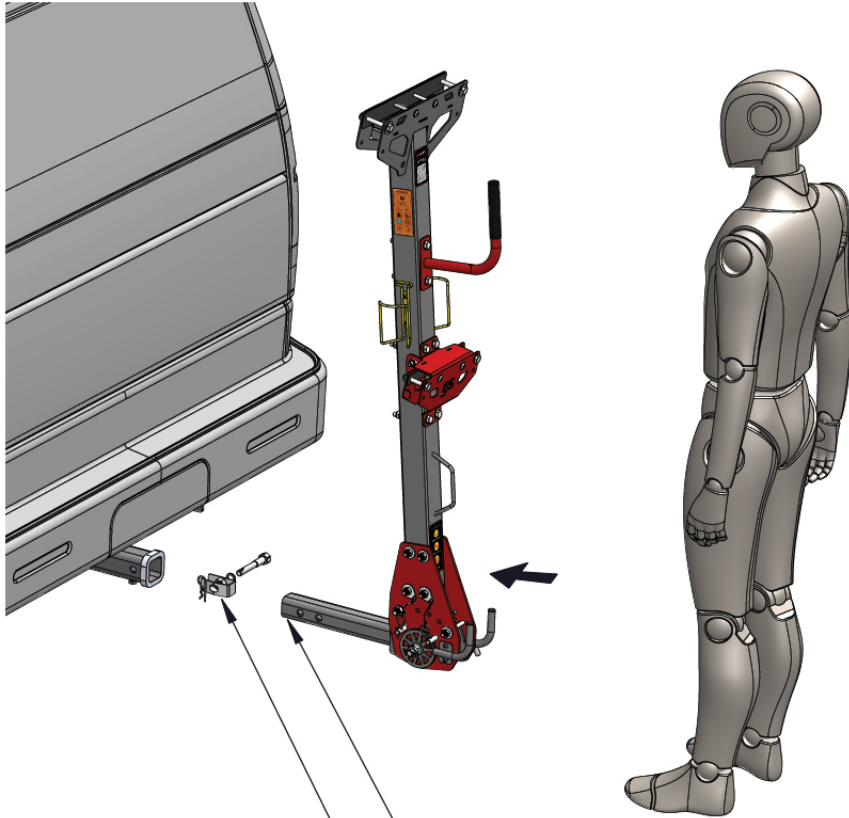

**KEEP VERY TIGHT  
CHECK REGULARLY  
OVER ROUGH TERRAIN**

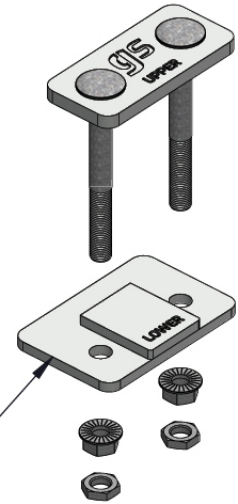

Hitch Clamp

(a) Insert Hitch Stabiliser into Bike Rack Hitch Arm. See diagram on pack for directions.

(b) Insert Bike Rack Hitch Arm into vehicle hitch up to desired position and secure accordingly. Tighten the Safety Pin and fit the supplied R Clip.

(c) Fit the Hitch Clamp over the top/bottom of the protruding Hitch Arm, making sure to catch the bottom edge of the Tow Bar Hitch with the Lower Plate. The Upper Plate only rests on top of the Bike Rack Hitch Arm.

Alternatively, you may wish to sit the Mast assembly on the ground, resting securely against a bench, or similar. Take care not to scratch the underside of the Hitch Hub.

## The installation should look like this below:

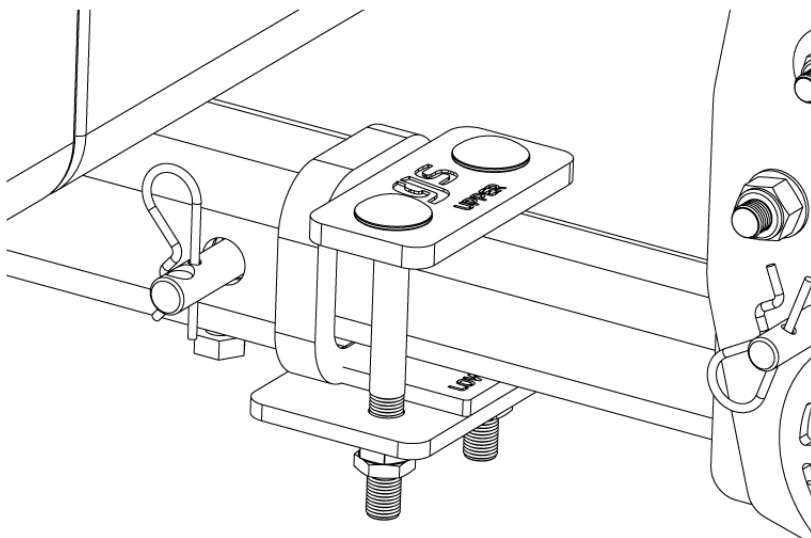

Secure the large nuts underneath, one after another until tight, pulling the rack downwards. Advance the nuts to a very tight limit.

Once the nuts are both equally very tight, screw on the thin locking nuts, and nip up to avoid large nuts loosening.

**Recommend 60% of tow bar down rating including rack & bikes**

Vehicle & Tow Bar combination	Towball down-weight limit	60% of down-weight limit	Rack	Bikes	Total Load	Suitable?
eg; Ford Ranger + towing pack & towbar	350kg	210kg	40kg	4x25kg = 100kg	140kg	Yes
eg; Nissan Xtrail SUV + Class 4 Tow Bar	200kg	120kg	40kg	4x25kg = 100kg	140kg	No
eg; Nissan Xtrail SUV + Class 4 Tow Bar	200kg	120kg	40kg	3x25kg = 75kg	115kg	Yes
eg; Nissan Xtrail SUV + Class 4 Tow Bar	200kg	120kg	40kg	4x20kg = 80kg	120kg	Yes



## 2. Fit the Wheel Baskets on the XBoom

**gripsport**

- Remove loosely fitted M8x75 Bolts, Washers, Dog Bones, Nyloc Nuts from XBoom Arm.
- Arrange Wheel Baskets to regular or staggered arrangement as desired by noting the front, middle or back position of the round hole on the Wheel Basket base plate.
- The slotted hole can then be secured, noting the inward pointing angle for the Wheel Basket arrangement. The slotted hole can also be used for fine adjustment of bike clearances if needed.
- Tighten M8 bolts to very firm (do not overtighten causing washers to deform). Inboard 2 bolts must be done once in position on Mast.

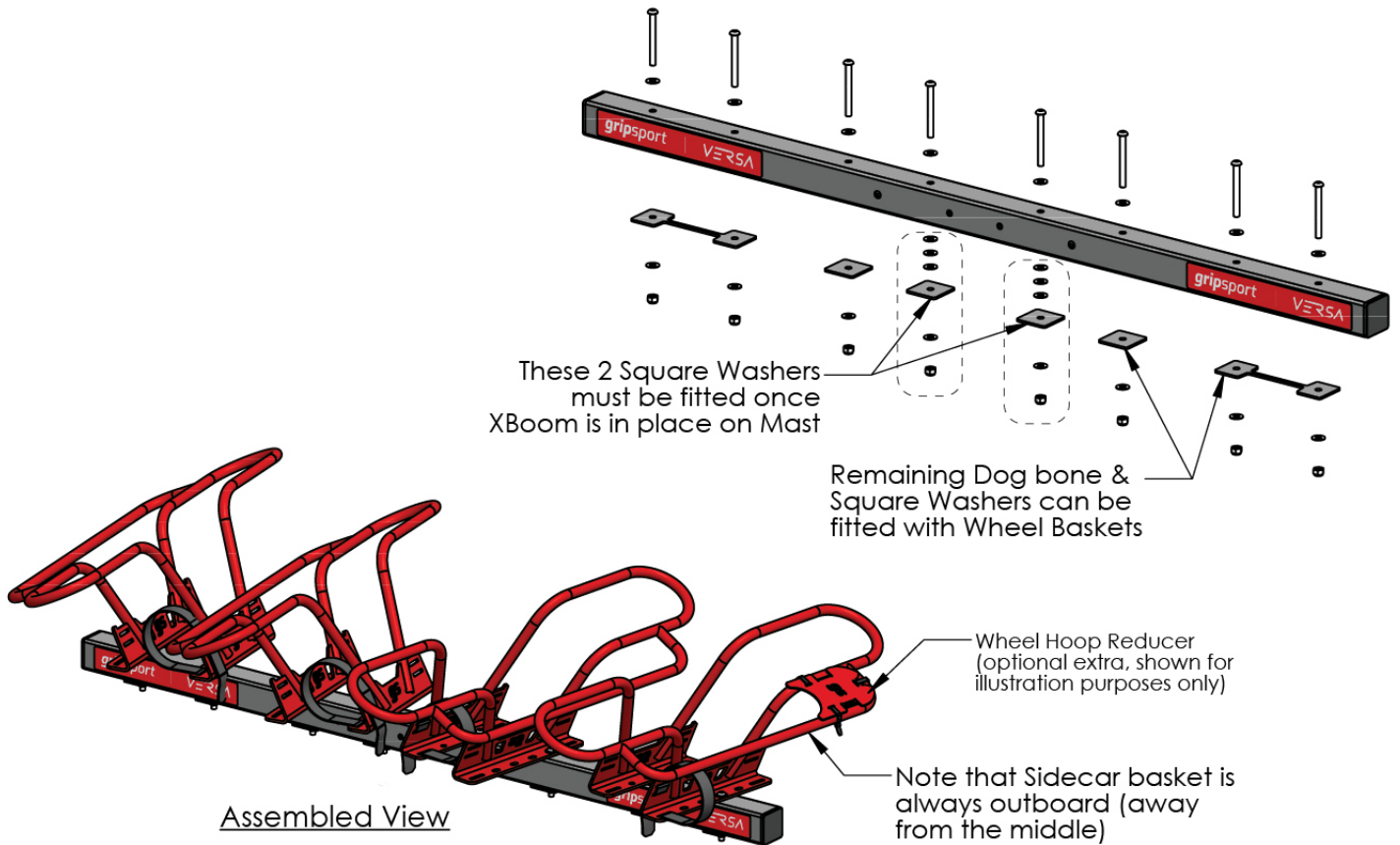

### Suggested Wheel Basket Layout (Staggered)

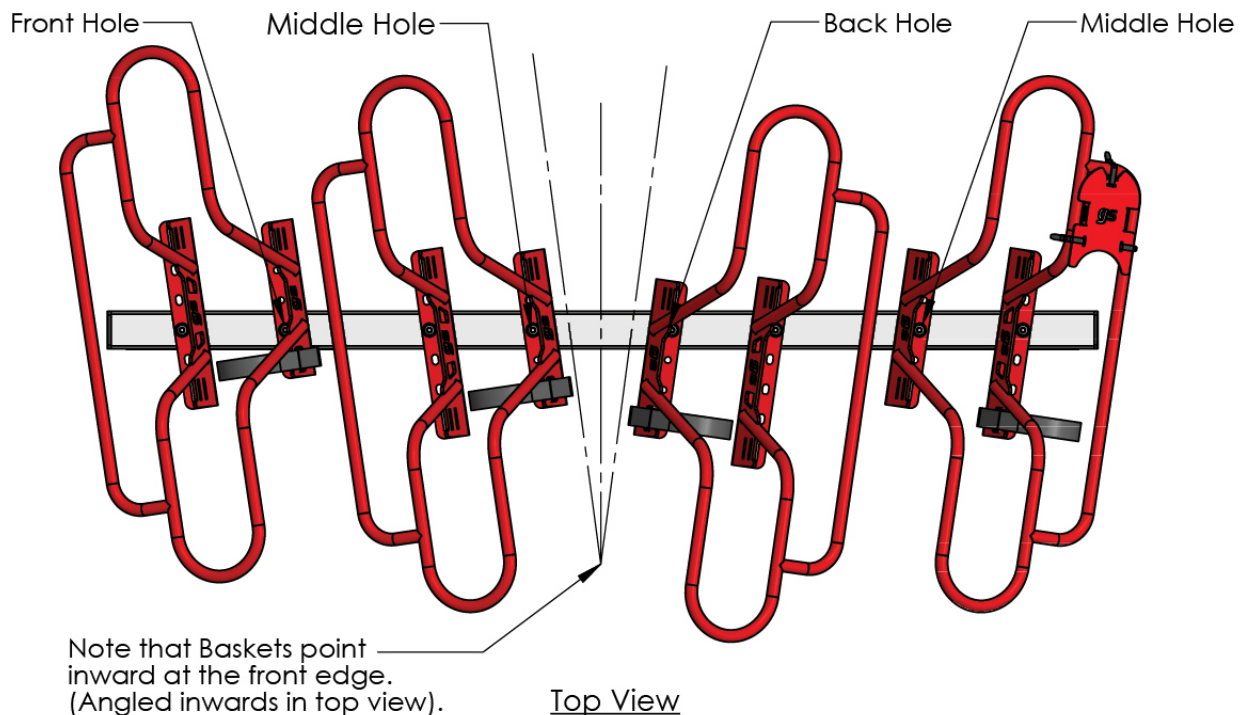



### 3. Fit XBoom to Mast

- (a) Remove loosely fitted Large and Small Bolt pairs (2@ M10x75 & 2@ M8x75), Washers and Nyloc Nuts from Mast triangle.
- (b) Place XBoom Arm into Mast triangle & black Plastic Liner. Position carefully to ensure all holes line up across Mast, Plastic Liner & XBoom Arm. (Inboard Wheel Basket fixings **NOT YET fitted**)
- (c) Loosely fit Large and Small Bolt pairs (2@ M10x75 & 2@ M8x75), Washers and Nyloc Nuts. Once all 4 bolts are in place, tighten firmly. Recheck with a final nip-up.
- (d) Finally, secure inboard Wheel Baskets with fixings & tighten firmly (2@ M8x75 Bolts, Washers, Square Washers and Nyloc Nuts).

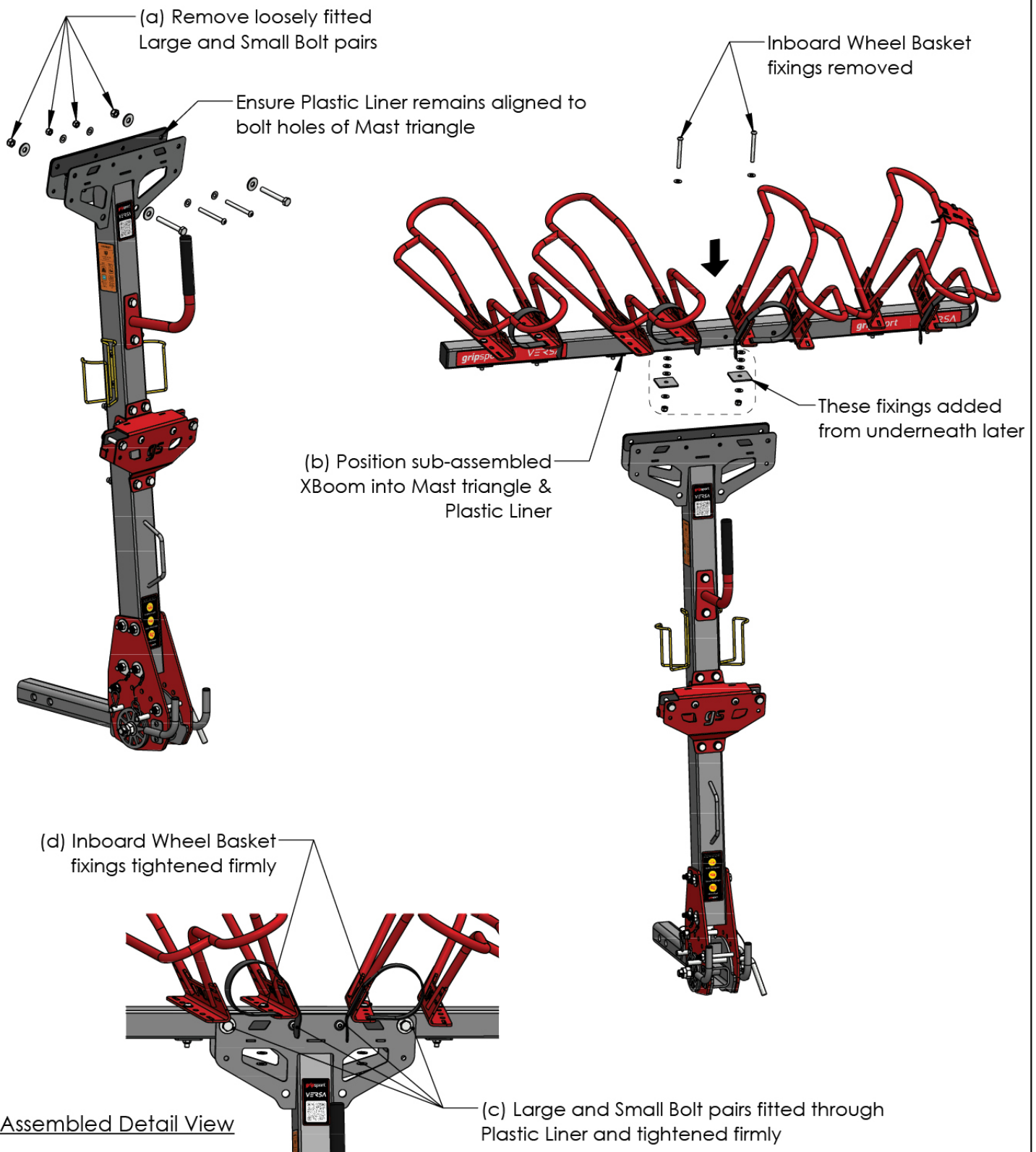

## 4. Install XRigger Arm

- (a) Remove loosely fitted Large and Small bolt pairs (2@ M10x60 & 2@ M8x60), Washers and Nyloc Nuts from XRigger Bracket.
- (b) Slide XRigger Arm into XRigger Bracket. Position carefully to ensure all holes line up across XRigger Bracket, Plastic Liner and XRigger Arm.
- (c) Loosely fit Large and Small Bolt pairs (2@ M10x60 & 2@ M8x60), Washers and Nyloc Nuts. Once all 4 bolts are in place, tighten firmly. Recheck with a final nip-up.

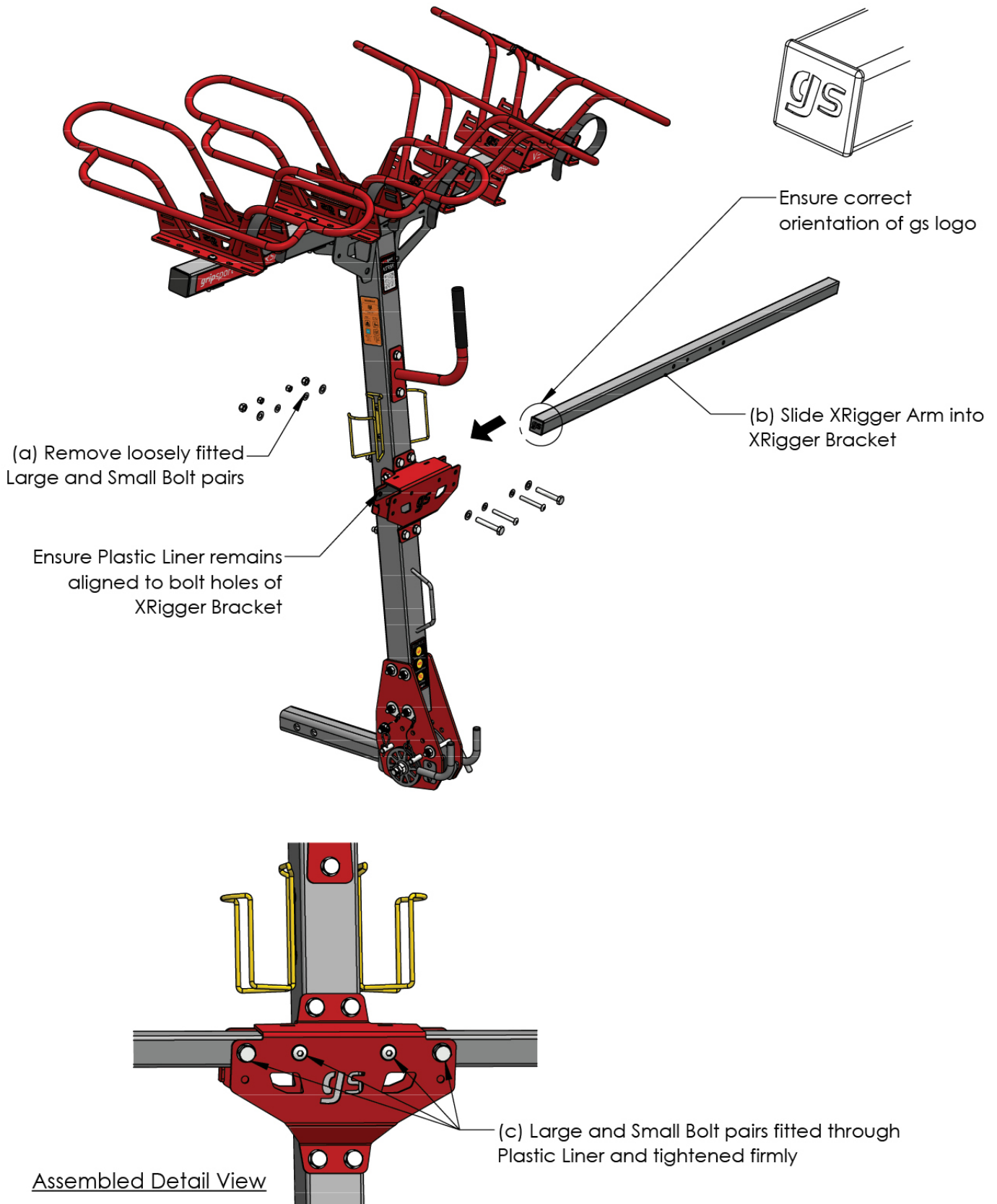





## 6. Fitting Rack Light

**gripsport**

- Slide Rack Light onto Mount Posts (if shipped loose, then affix with 4@ M6x10 & washers). Press spring buttons to allow complete insertion and ensure both spring buttons pop out to secure in final position.
- Connect Wiring Lead to Rack Light tail cable.
- Connect Wiring Lead 7 Pin Flat Plug to vehicle. An adapter may be required if vehicle has round or other style of plug.

Excess cable may be wrapped through the lock-grab handle to avoid dragging/catching during transport. Ensure enough slack is present to allow rack tilting without overstretching cable.

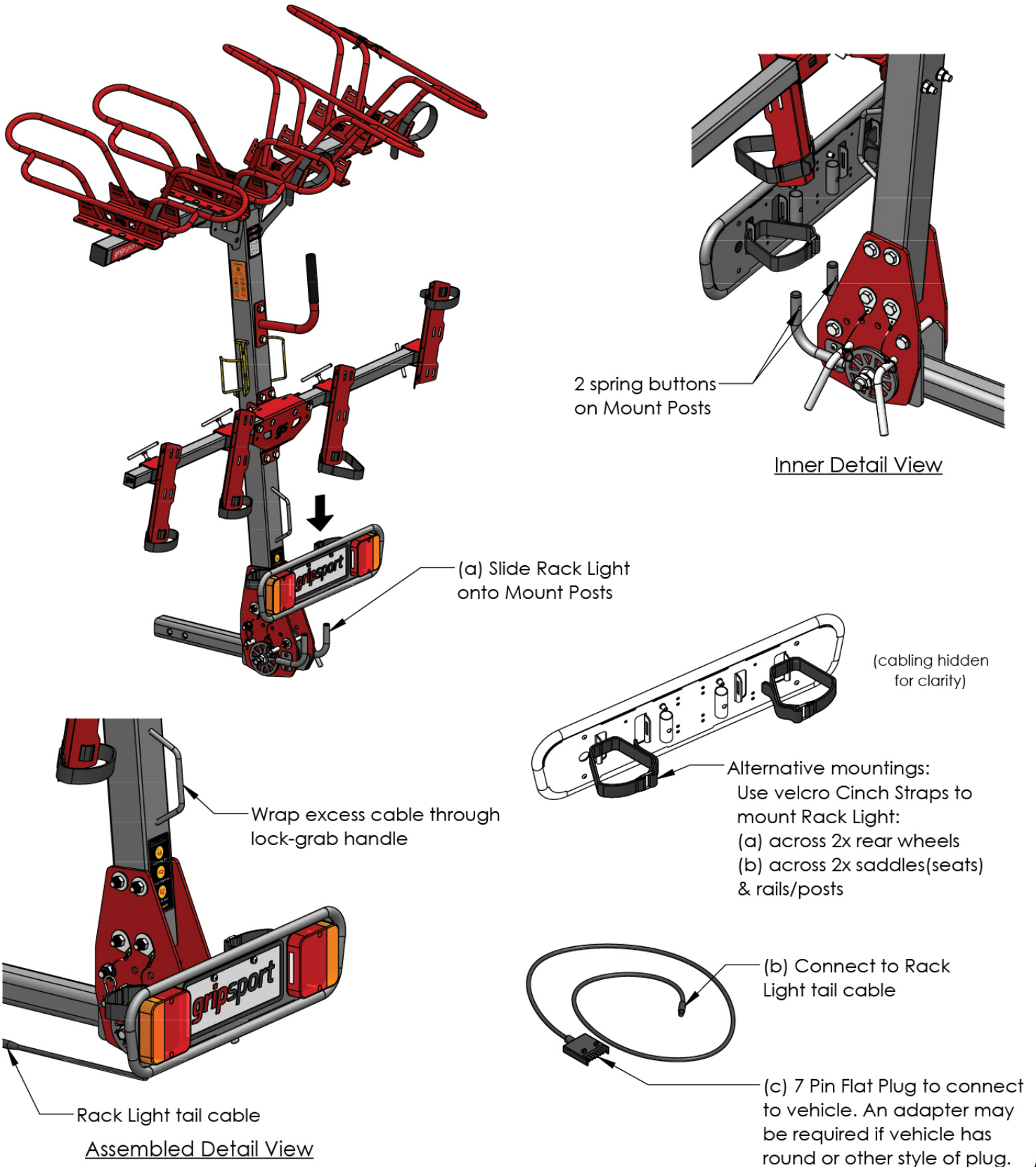

## 7. Hub Details & Tilting Rack

**gripsport**

- Remove Twin Pins to enable rack tilt. This should be carried out with an empty rack to start, to get familiar with handling the rack. The R-Clips will need to be removed first.
- Using Handle Grip on Mast from a standing position, tilt rack downwards until Drop-Stop Bolt limit is reached. The motion should be smooth and without any loose vibration, thanks to the Pressure Wheel and Pivot Shaft. These components are under high tension and should not be adjusted.
- To replace rack to upright and driving position, tilt up until Back-Stop Bolt limit is reached. Keeping the left hand pushing on the Handle Grip, use the right hand to successively replace the Twin Pins. The tether wire ropes ensure this is a one-handed operation.
- Releasing the Left Hand from the Handle Grip, replace the R-Clips into the Twin Pins.

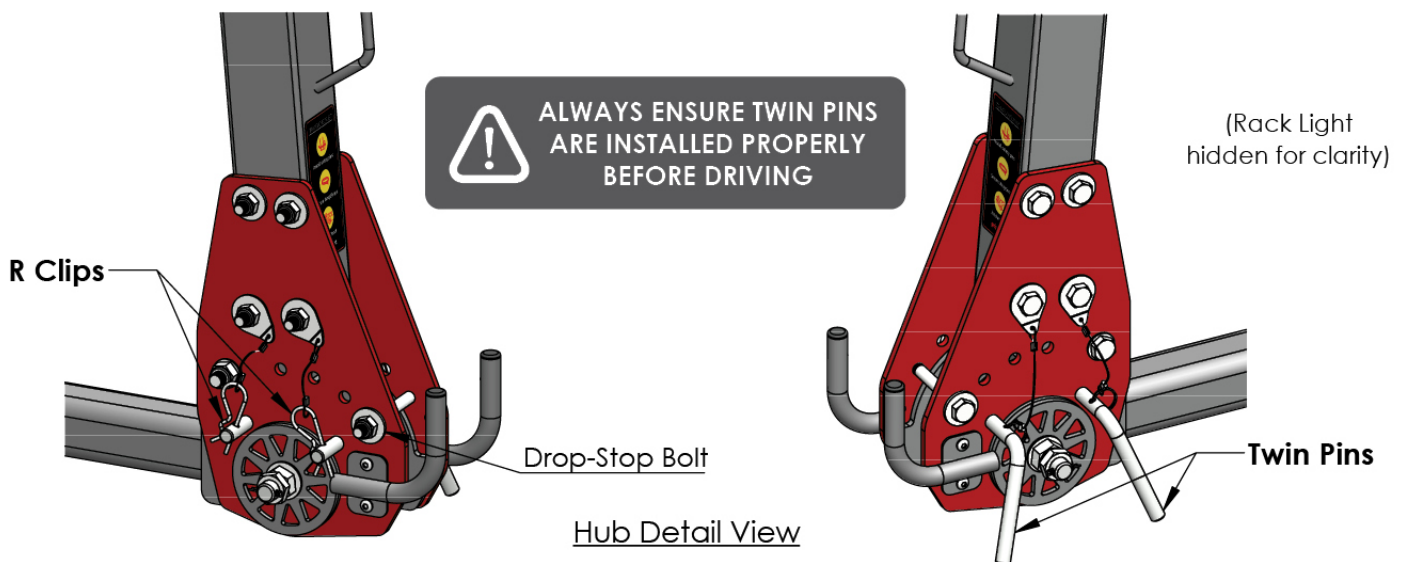

The Drop-Stop Bolt can be repositioned to enable additional vehicle boot/tailgate access. Only gentle tension is required on this bolt.

**Do not make very tight, as side plates will progress to bending.**

Remove Drop-Stop Bolt completely for track-stand position. Exercise extreme caution in this case, as rack will fall completely to ground if not carefully controlled.

Tilting to the first hole is generally safe. It is not recommended to tilt lower than the first hole if:

- 1 person is tilting with 2 or more bikes
- 2 people are tilting with 3 or more bikes
- Heavy bikes loaded will decrease these guidelines and should be tested gradually with additional people to support.

**If in doubt, remove bikes from rack - then tilt for vehicle access!**

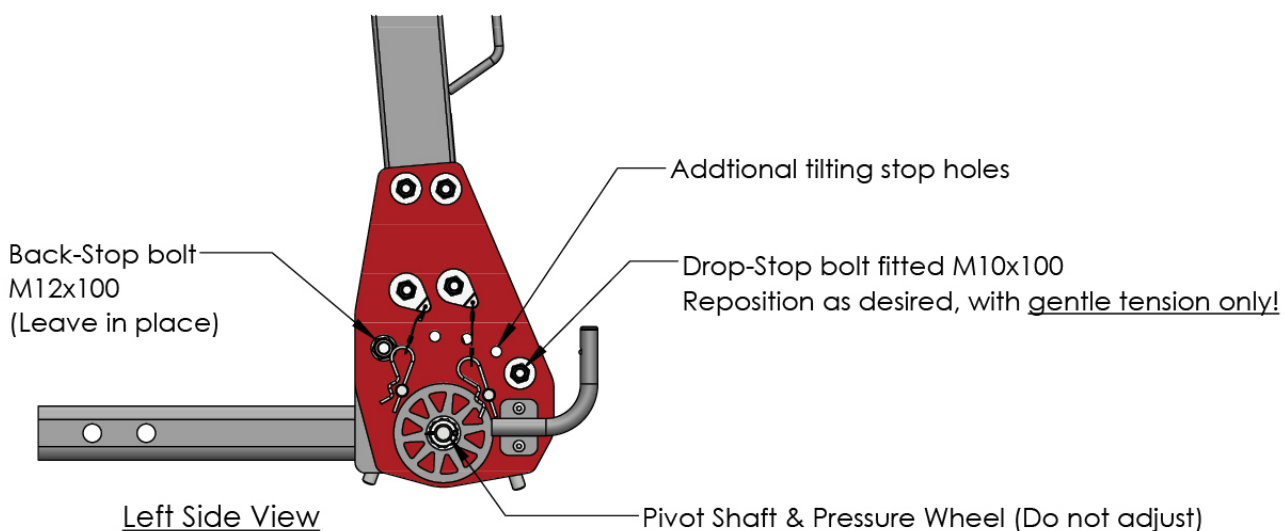

## 8. Load Bike & WrapStraps

**gripsport**

- Open velcro of WrapStraps on both the Wheel Basket and Taquito, so straps are loose in mid-air.
  - Lift bike up and slot front wheel into desired Wheel Basket channel. Lifting by fork and seat stay is often best. Turn Handlebars so that tyre is resting next to WrapStrap. The weight of the bike will now be taken.
  - Thread the Wheel Basket WrapStrap through the wheel in between spokes and pull tight, finally pressing velcro down onto strap backing. WrapStraps are designed to work as a "full circle", wrapping in a loop.
  - Move rear wheel onto Taquito channel.
  - Thread the Taquito WrapStrap through the wheel and secure as per previous method.
- Repeat for all other bike spots as necessary. Confirm all bikes are firmly in position with a quick bike shake.

Note:

- All tyres must be pumped up sufficiently to avoid wheel/rack damage.
- **Axles/skewers (especially front wheel) must be securely fastened into bike frame/fork - else bike may fall!!!**



(b) suggested lifting points for light bikes.  
2-person lift advised for heavy or awkward situations.

**ALWAYS ENSURE ALL WRAPSTRAPS ARE FITTED BEFORE DRIVING!!**

(c) WrapStrap pulled tight and flattened onto strap backing

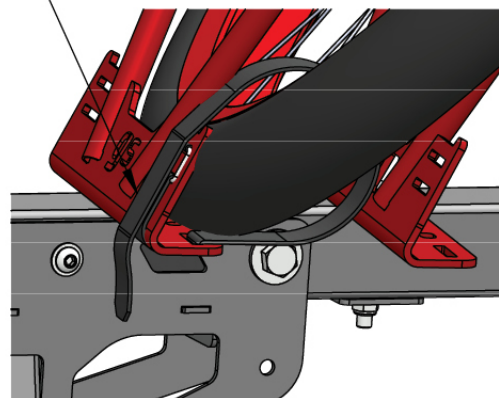

Wheel Basket WrapStrap Fitted View

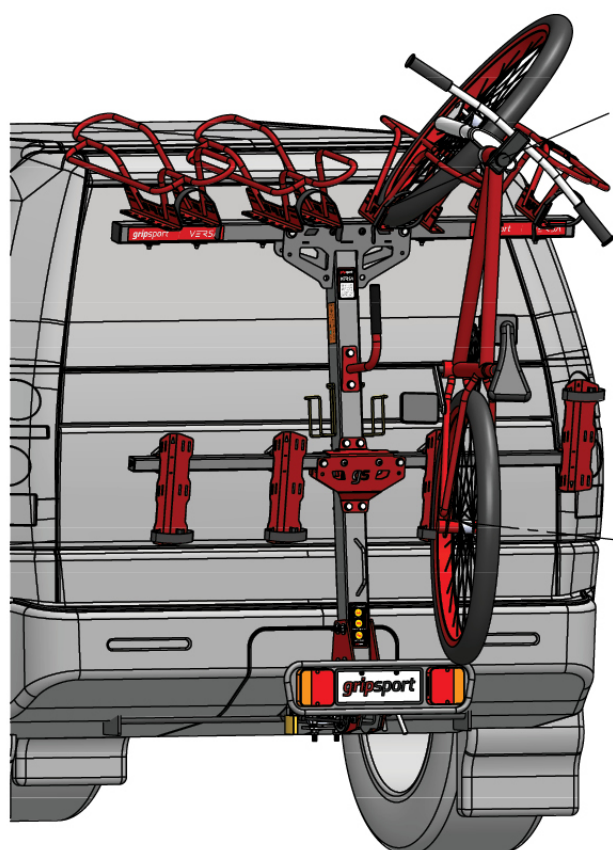

Bike Fitted View

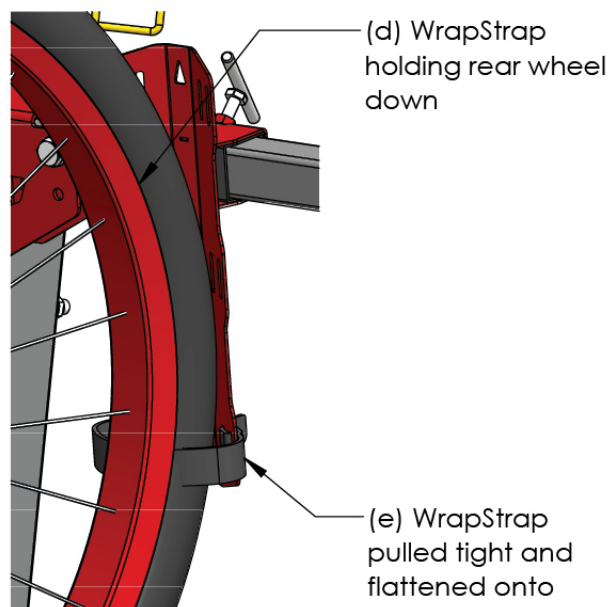

Taquito WrapStrap Fitted View